

## FSP SERIES LENSES

for **SEOUL SEMICONDUCTOR Z-POWER P3™ LEDs**

- High efficiency
- Available in 2 different beams
- Patent Pending

The FSP series offers low profile lenses especially designed for the Seoul Semiconductor LEDs : Z-Power P3™.

[www.seoulsemiconductor.com](http://www.seoulsemiconductor.com)

A software-optimized aspheric profile combined with front shaped micro-lens arrays enable the generation of two beam output patterns: narrow and medium.

The high collection efficiency reaches 85% of the total flux emitted from the LED.

Lens holders are available and provide the proper alignment between the LED and lens.

Heat staking the four legs of the holder to the customer's PCB or heat sink provides excellent optical and mechanical assembly (see Fraen Application Note FAN01-EN (at [www.fraensrl.com](http://www.fraensrl.com))).

Typical applications are:

- Reading lamps
- Signs
- Architectural Lighting
- Street Lights
- Most application where uniformity and high intensity over a wide angle is required.



(1) Z-Power is a trademark of Seoul Semiconductor. For technical specification on LEDs please refer to the Z-Power datasheet or visit [www.seoulsemiconductor.com](http://www.seoulsemiconductor.com)

*For ordering instructions, please contact*

### FRAEN CORPORATION

Scott M. Grzenda  
80 Newcrossing Road  
Reading MA 01867  
Phone: 781.205.5300  
Fax: 781.942.2426  
[optics@fraen.com](mailto:optics@fraen.com)

### FRAEN Srl

Dimitri De Gaetano  
Via E. Fermi, 7  
20090 Settimo M (MI) – Italy  
Phone: +39-02-335.456.225  
Fax: +39 02-335.456.239  
[info@fraen.com](mailto:info@fraen.com)

*To find a local distributor, check the Fraen website.*

Website: [www.fraensrl.com](http://www.fraensrl.com)



## General Characteristics

---

Lens Material	Optical Grade PMMA
Holder Material	PC ABS
Operating Temperature range	-40deg C / + 80 deg C
Storage Temperature range	-40deg C / + 80 deg C

Average transmittance in visible spectrum (400 – 700nm) >90%, as measured using 3mm thick Optical Grade PMMA.

*Please note that flow lines and weld lines on the external surfaces of the lenses are acceptable if the optical performance of the lens is within the specification described in the section "OPTICAL CHARACTERISTICS"*

### **IMPORTANT NOTE – Lenses handling and cleaning:**

*Handling: Always use gloves to handle lenses and/or handle the lenses only by the flange. Never touch the outside surfaces of the lenses with fingers; finger oils and contamination will absorb or refract light.*

*Cleaning: Clean lenses only if necessary. Use only soap and water to clean the surfaces and lenses. Never expose the lenses to alcohol, as it will damage the plastic.*



## Optical Characteristics:

---

		Typical total divergence* (degrees)			
Lens Part Number	Type of lens	Blue LEDs ●	Green LEDs ●	Red LEDs ●	White LEDs ○
FSP-HNB1-SSP3-z	Narrow beam	18.0	13.0	8.5	13.0
FSP-HMB1-SSP3-z	Medium beam	16.5	17	16	19

- The typical divergence varies with LED color due to different chip size and chip position tolerance.
- The typical total divergence is the full angle measured where the luminous intensity is half of the peak value.

		Typical on-axis efficiency* (cd/lm) (3)(4)			
Lens Part Number	Type of lens	Blue LEDs ●	Green LEDs ●	Red LEDs ●	White LEDs ○
FSP-HNB1-SSP3-z	Narrow beam	7.2	13.1	19.0	10.0
FSP-HMB1-SSP3-z	Medium beam	5.0	7.7	4.6	5.5

- (2) To calculate the on-axis intensity, multiply the on-axis efficiency of the lens (cd/lm) by the total flux of the Z-Power LED used. For more detail on flux binning please check the Z-Power LED datasheet at <http://www.seoulsemiconductor.com/>.
- (3) Luminous intensity depends on the flux binning and tolerances of the LEDs. Please refer to the Z-Power datasheet for more details on flux binning and mechanical tolerances.

## Mechanical Characteristics

---

The FSP series of lenses has been specifically optimized for the Z-Power LEDs. For best optical performance (shown above), correct mechanical position of the lens on the LED is critical.

The FSP lenses can be used either **alone** or **with its unique holder**.

### View of the assembly with the lens (if no holder is used):

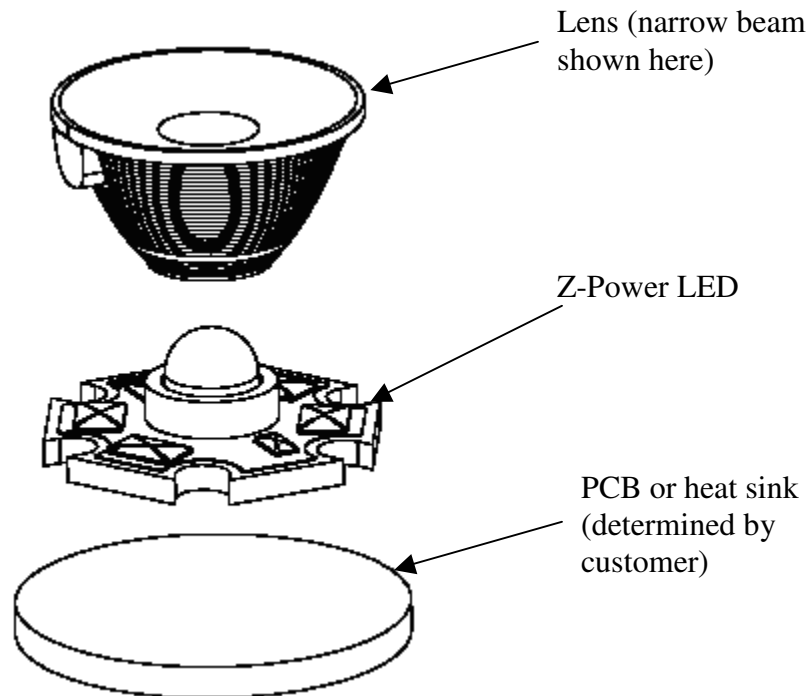

**Assembly with the lens (if no holder is used):**

The bottom of the lens sits on the ring of the Z-Power LEDs

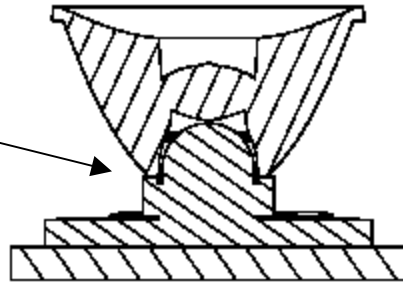

B-B

This dimension represents the distance from the top of the lens to the bottom of the Z-Power.

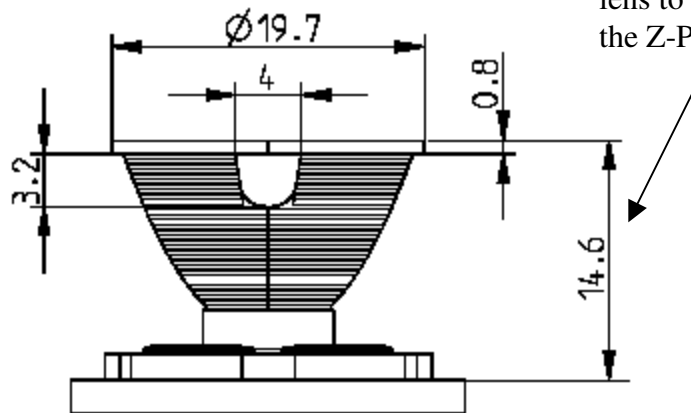

Dimensions tolerance is +/-0.2mm

The outside mechanical dimensions of the lenses (Narrow and Medium beam) are the same, except the front of the lens. The lens can be recognized by the front view:

Front views:

Narrow beam lens

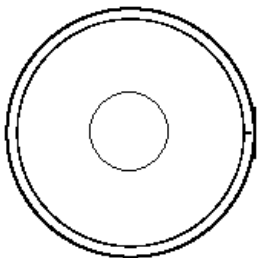

Medium beam lens (*light texture\* on the front of lens*)

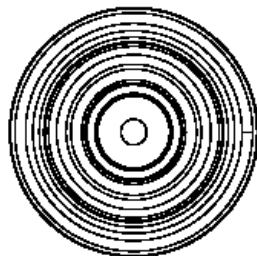

*Light texture on the micro-lenses improves evenness of the beam.*

**Lens + holder assembly view and dimensions:**

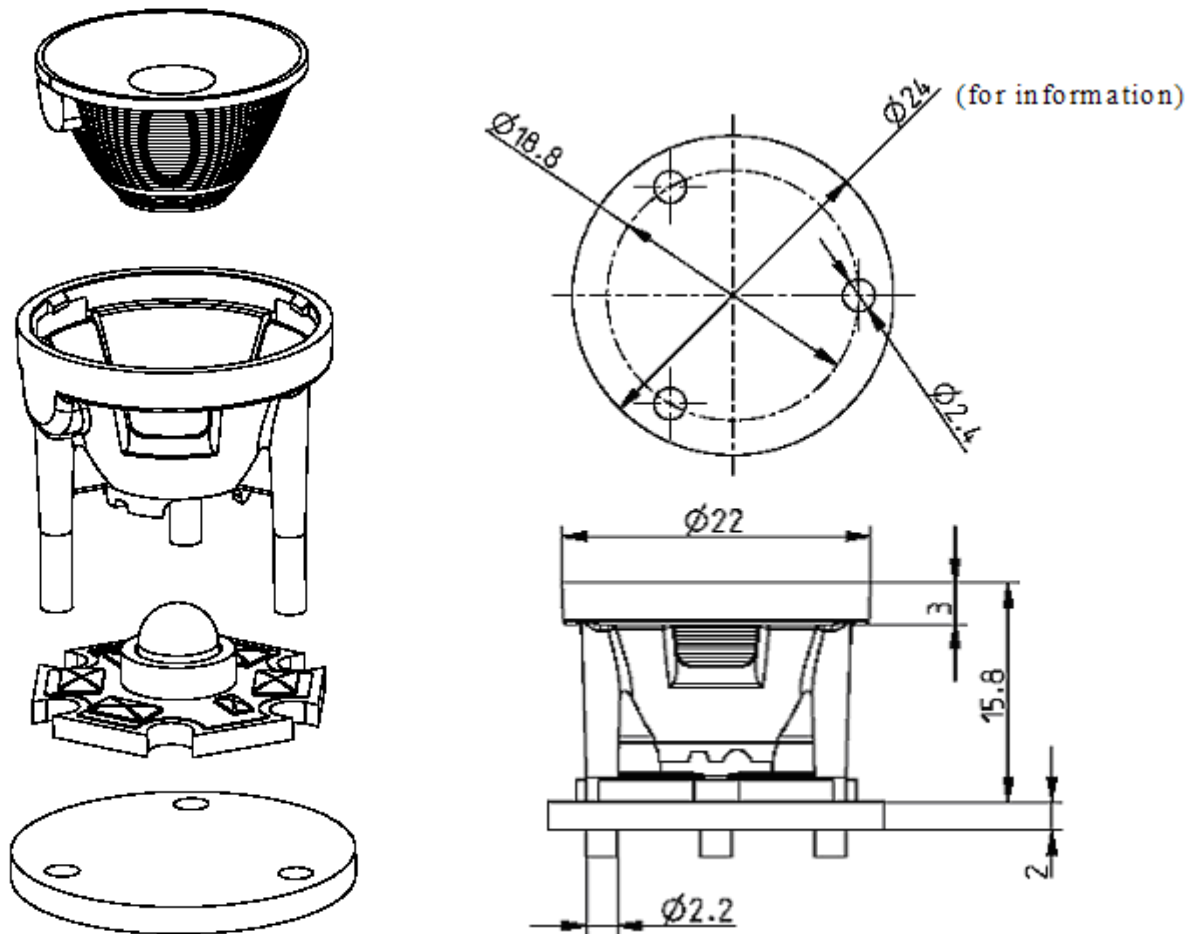

Dimensions tolerance is +/-0.2mm



## Ordering part numbers

---

FSP-HxB1-SSP3-z

**OPTIONS:**

0 = without holder  
H = with holder

**LENS TYPE:**

N = Narrow beam lens  
M = Medium beam lens

Published by Fraen Corporation.

All data contained in this document is the property of Fraen Corporation and may change without notice.

### Document Revision Record

Rev	Date	Author	Description
00	08-17-2006	S.A.H.	Initial Release
01	08-23-2006	S.A.H.	Replaced preliminary lens data with production lens data